

ACUROS[®] 6 CQD[®] ESWIR Core

Advance Information

ACUROS6-ESWIR-CORE-GEVK

SWIR IMAGING MEETS HIGH RESOLUTION:

SWIR Vision Systems continues the tradition of lowest cost per megapixel with the ACUROS 6 eSWIR Core. The compact, lightweight design delivers a spectral response from Visible up to 2.1 μm and is equipped with 7 μm pixels featuring optically enhanced CQD technology for improved SNR performance. A single-stage TEC ensures stable performance over a wide range of operating conditions.

THE POWER OF 6 MP

Higher resolution is essential for imaging, capturing intricate details with wider fields of view. This additional data is vital to precision-driven industries like medical, manufacturing, scientific research and defense and aerospace. The ACUROS 6, high-resolution sensor, enables post-processing flexibility with lower loss of quality, empowering users, and algorithms to extract insights, spot defects, and enhance images for more meaningful results.

SPECIFICATIONS

Table 1. SENSOR FEATURES

Parameter	Value/Description	
Type	ACUROS 6 CQD sensor	
Pixel Pitch	7 μm	
Format	2908 x 2040	
Array Size	20.36 mm x 14.28 mm	
Array Diagonal	24.87 mm	
Shutter	Global Shutter	
Max FPS (full frame)	100 Hz (8 bit), 50 Hz (12 bit)	
Min Exposure Time	10 μs	
Detector Technology	Colloidal quantum dot photodiode	
Detector Type	eSWIR	
Spectral Range	400–2100 nm	
QE	>15% @ 1900 nm typical	
Pixel Operability	>99.75% typical	
Dark Noise (at 30 °C)	TBD (e ⁻ /s)	
Dark Noise Doubling Temp	9 °C	
Analog Gain Modes	Low Gain	High Gain
Read Noise	125 e ⁻	20 e ⁻
Well-Depth	350 Ke ⁻	52 Ke ⁻
Dynamic Range	68 dB	63 dB
ADC Bit Depth	8-bit or 12-bit	

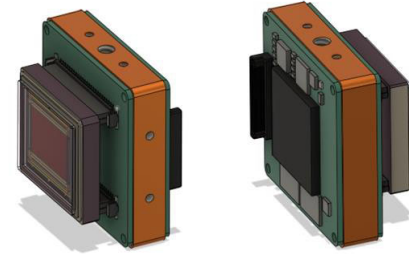

CSNSR
 CASE 811AB

ORDERING INFORMATION

Part Number
ACUROS6-ESWIR-CORE-GEVK

Features

- Compact Form Factor
- CameraLink LVDS Interface
- Auto Exposure
- Dynamic Non-Uniformity Correction (NUCs)
- GenICam Compliant
- TEC Thermal Stabilization
- Spectral Range Covering 400 nm – 2100 nm

Applications

- Machine Vision
- Silicon Inspection
- Laser Beam Profiling
- Automotive
- Surveillance
- Hyperspectral
- Chemical Sensors
- Agricultural
- Medical Imaging
- Thermography

This document contains information on a new product. Specifications and information herein are subject to change without notice.

ACUROS6-ESWIR-CORE-GEVK

Table 2. CORE FEATURES

Parameter	Value/Description
Trigger	External TTL
Region of Interest (ROIC)	Yes (8 row increments)
ROI FPS Scaling	Yes. FPS up to 10 kHz for 3064 x 8 pixel ROI
Binning Arrays	Yes
Non-Uniformity Correction	2 pt
Auto Exposure Control	Yes

Table 3. ENVIRONMENTAL & POWER SPECIFICATIONS

Parameter	Value/Description
Sensor Temperature Stabilization	Single-stage TEC
Operating Case Temperature	-20 °C to +55 °C
Storage Temperature	-10 °C to +55 °C
Power Consumption	TBD
Power Supply Voltage	TBD

Table 4. MECHANICAL SPECIFICATIONS

Parameter	Value/Description
Dimensions Excluding Lens	5 cm x 5 cm x 3.8 cm
Weight Excluding Lens	200 g estimated
Connector	Samtec Razor Beam (LSHM)

Table 5. SOFTWARE AND USER INTERFACE

Parameter	Value/Description
Interface	CameraLink LVDS

ACUROS6-ESWIR-CORE-GEVK

PACKAGE DIMENSIONS

CSNSR 51.00x51.00x27.22
CASE 811AB
ISSUE O

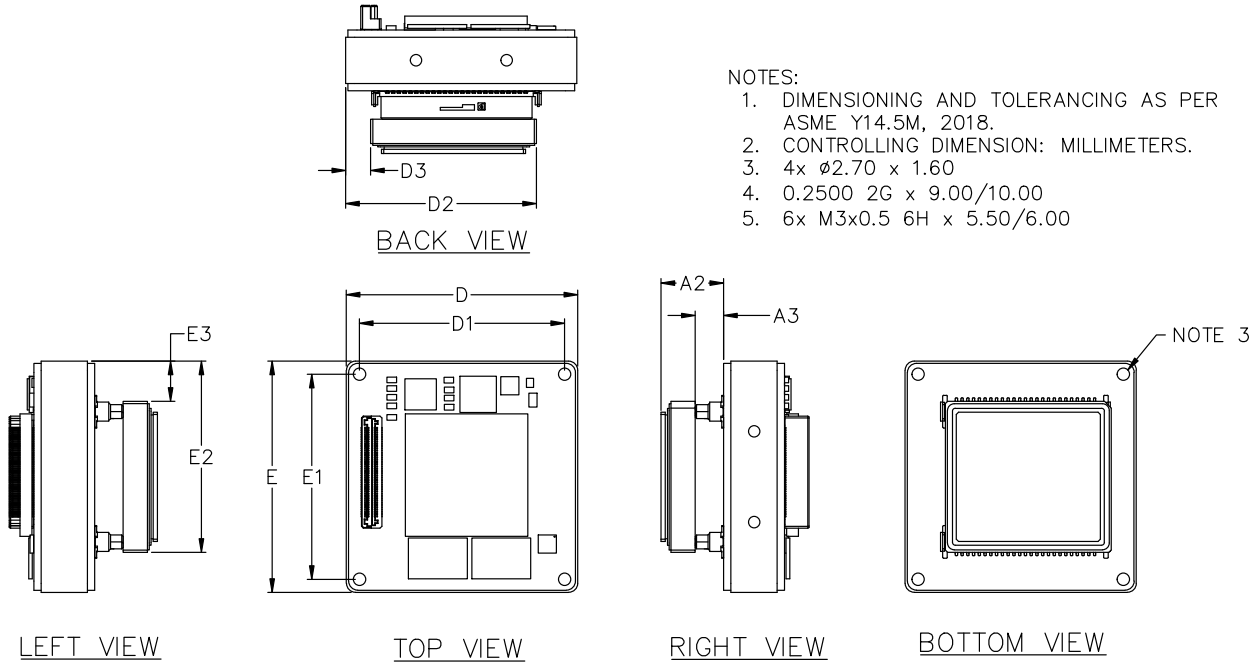

- NOTES:
1. DIMENSIONING AND TOLERANCING AS PER ASME Y14.5M, 2018.
 2. CONTROLLING DIMENSION: MILLIMETERS.
 3. 4x $\phi 2.70 \times 1.60$
 4. 0.2500 2G x 9.00/10.00
 5. 6x M3x0.5 6H x 5.50/6.00

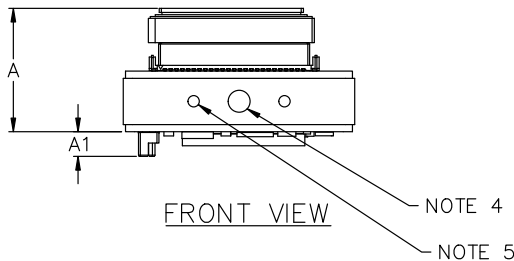

MILLIMETERS			
DIM	MIN	NOM	MAX
A	27.12	27.22	27.32
A1	5.32	5.42	5.52
A2	13.72	13.82	13.92
A3	6.18	6.28	6.38
D	50.90	51.00	51.10
D1	45.15	45.25	45.35
D2	42.01	42.11	42.21
D3	5.41	5.51	5.61
E	50.90	51.00	51.10
E1	45.15	45.25	45.35
E2	42.05	42.15	42.25
E3	8.75	8.85	8.95

ACUROS, CQD and SWIR VISION SYSTEMS are registered trademarks of Semiconductor Components Industries, LLC dba "onsemi" or its affiliates and/or subsidiaries in the United States and/or other countries.

All other brand names and product names appearing in this document are registered trademarks or trademarks of their respective holders.

onsemi, Onsemi, and other names, marks, and brands are registered and/or common law trademarks of Semiconductor Components Industries, LLC dba "onsemi" or its affiliates and/or subsidiaries in the United States and/or other countries. onsemi owns the rights to a number of patents, trademarks, copyrights, trade secrets, and other intellectual property. A listing of onsemi's product/patent coverage may be accessed at www.onsemi.com/site/pdf/Patent-Marking.pdf. onsemi reserves the right to make changes at any time to any products or information herein, without notice. The information herein is provided "as-is" and onsemi makes no warranty, representation or guarantee regarding the accuracy of the information, product features, availability, functionality, or suitability of its products for any particular purpose, nor does onsemi assume any liability arising out of the application or use of any product or circuit, and specifically disclaims any and all liability, including without limitation special, consequential or incidental damages. Buyer is responsible for its products and applications using onsemi products, including compliance with all laws, regulations and safety requirements or standards, regardless of any support or applications information provided by onsemi. "Typical" parameters which may be provided in onsemi data sheets and/or specifications can and do vary in different applications and actual performance may vary over time. All operating parameters, including "Typicals" must be validated for each customer application by customer's technical experts. onsemi does not convey any license under any of its intellectual property rights nor the rights of others. onsemi products are not designed, intended, or authorized for use as a critical component in life support systems or any FDA Class 3 medical devices or medical devices with a same or similar classification in a foreign jurisdiction or any devices intended for implantation in the human body. Should Buyer purchase or use onsemi products for any such unintended or unauthorized application, Buyer shall indemnify and hold onsemi and its officers, employees, subsidiaries, affiliates, and distributors harmless against all claims, costs, damages, and expenses, and reasonable attorney fees arising out of, directly or indirectly, any claim of personal injury or death associated with such unintended or unauthorized use, even if such claim alleges that onsemi was negligent regarding the design or manufacture of the part. onsemi is an Equal Opportunity/Affirmative Action Employer. This literature is subject to all applicable copyright laws and is not for resale in any manner.

ADDITIONAL INFORMATION

TECHNICAL PUBLICATIONS:
Technical Library: www.onsemi.com/design/resources/technical-documentation
onsemi Website: www.onsemi.com

ONLINE SUPPORT: www.onsemi.com/support
For additional information, please contact your local Sales Representative at www.onsemi.com/support/sales